

## Electrically Operated, Continuously Hinged (Train) Panels

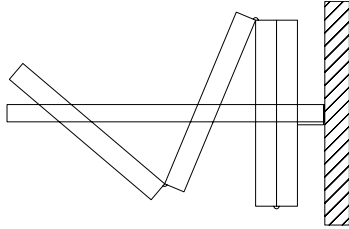

**Top Supported  
Center Stack  
Continuously Hinged Panels  
Electrically Operated**  
**Maximum Height:** 30'3" [9.2m]  
**Standard Opening Width:**  
w/Retractable bottom seals:  
100' [30.48m] single partition  
w/Continuous contact bottom seals:  
157' 4" [47.9]  
**STC Ratings:** 43, 47, 49, 52, 54

### PRODUCT OVERVIEW:

**Select for Durability, Aesthetics:** The 643E offers panel finishes for the ultimate in design flexibility. Even the frames may be color matched to coordinate with the faces. The 643E is a popular choice for hotel meeting rooms, convention centers, commercial facilities, or other high use facilities.

**Standard Features:** The panels are nominally 4" [101] thick, and have a 16 ga. steel frame. The top horizontal sound seal is of multi-finger vinyl, and the bottom sound seal is retractable and provides up to 2" [50] floor clearance (to accommodate out-of-level floors). The faces may be covered from a wide selection of vinyl colors and patterns. The face substrate varies by the level of sound control required (STC rating).

**Electric, Continuously Hinged (Train) Panels:** Panels are hinged together and are operated by two electric key switches for fast, safe set-up.

**How to Obtain:** Hufcor partitions are sold, installed, and serviced by factory-trained local authorized Distributors in the United States and by Licensees and Distributors outside the U.S.A.

**Delivery:** Panels are custom built for your specific project. Lead times vary due to seasonal fluctuations. Check with your Distributor for the current schedule.

**Warranty:** Track and panels are guaranteed for **two years** against defects in material and workmanship.

### "Standard" Product Features and Benefits:

Look for these features when comparing similar products.

- Feature:** Protective vertical trim (Available option: no vertical face trim.)  
**Benefit:** Trim protects the panel edges and faces.
- Feature:** Mechanically retracted bottom seals  
**Benefit:** Partition travels across the opening without causing damage to the floor and accommodates deflection and floor variance.
- Feature:** Bottom seal system with downward seal force.  
**Benefit:** Maintains acoustics over time and adds stability to the partition when extended. Completely retracts during movement to eliminate floor damage.
- Feature:** Carrier on each panel  
**Benefit:** Supports the weight of each panel and ensures smooth, even operation. Rub or guide rails not required.
- Feature:** Low profile hinges  
**Benefit:** Safety and aesthetics - no unsightly hinges protruding from the panel faces.
- Feature:** Two key-controlled switches required to operate.  
**Benefit:** Safety. There will be one operator on each side of the partition. Each can see if any person or obstruction is in the path of the partition during operation.
- Feature:** Emergency release (accessible from the floor in the stack area).  
**Benefit:** Enables movement of the partition in the event of power failure.
- Feature:** Interlocking vertical seals  
**Benefit:** Ensures panel-to-panel alignment and prevents sound leaks between panels.
- Feature:** Slow stop and start movement  
**Benefit:** Smooth and quiet operation for increased longevity of system.

#### Options:

Various accessories enable the standard product to be modified for optimum versatility. See details provided or ask your Hufcor representative for the features you want.



# GENERAL SPECIFICATIONS/SERIES 643E

## Electrically Operated, Continuously Hinged Operable Partitions

### **PART 1 - GENERAL**

#### 1.01 DESCRIPTION

##### A. General

1. Furnish and install operable partitions and suspension system.  
Provide all labor, materials, tools, equipment, and services for operable walls in accordance with provisions of contract documents.

#### 1.02 RELATED WORK BY OTHERS

- A. Preparation of opening will be by General Contractor. Any deviation of site conditions contrary to approved shop drawings must be called to the attention of the architect.
- B. All header, blocking, support structures, jambs, track enclosures, surrounding insulation, and sound baffles as required in 1.04 Quality Assurance.
- C. Prepunching of support structure in accordance with approved shop drawings.
- D. Paint or otherwise finishing all trim and other materials adjoining head and jamb of operable partitions.

#### 1.03 SUBMITTALS

- A. Complete shop drawings are to be provided prior to fabrication indicating construction and installation details. Shop drawings must be submitted within 60 days after receipt of signed contract.

#### 1.04 QUALITY ASSURANCE

- A. Preparation of the opening shall conform to the criteria set forth per ASTM E557 Standard Practice for Architectural Application and Installation of Operable Partitions
- B. The partition STC (Sound Transmission Classification) shall be achieved per the standard test methods ASTM E90.
- C. Noise isolation classifications shall be achieved per the standard test methods ASTM E336 and ASTM E413.
- D. Noise Reduction Coefficient (NRC) ratings shall be per ASTM C423.
- E. Rack testing for 10 years. (tensional strength stress test)
- F. The manufacturer shall have a quality system that is registered to the ISO 9001 standards.

#### 1.05 PRODUCT DELIVERY, STORAGE, AND HANDLING

- A. Proper storage of partitions before installation and continued protection during and after installation will be the responsibility of the General Contractor.

#### 1.06 WARRANTY

- A. Partition system shall be guaranteed for a period of two years against defects in material and workmanship, excluding abuse.

### **PART 2 - PRODUCTS**

#### 2.01 ACCEPTABLE MANUFACTURERS

- A. Upon compliance with all of the criteria specified in this section, Manufacturers wishing to bid products equal to the product specified must submit to the architect 10 days prior to bidding complete data in support of compliance and a list of three past installations of products similar to those listed. The submitting manufacturer guarantees the proposed substituted product complies with the performance items specified and as detailed on the drawings.

#### 2.02 MATERIALS

- A. Product to be top supported Series 643E electrically operated, continuously hinged panels as manufactured by Hufcor Inc.
  1. Panels shall be nominally 4" [101] thick, to 48-1/2" [1232] in width, and continuously hinged.
  2. Panel faces shall be laminated to appropriate substrate to meet the STC requirement in 2.04 Acoustical Performance.
    - a. Optional face material (Not all substrates are available for all STC ratings. Consult your Hufcor Distributor for more information):
      - Steel
      - Non-steel
      - Medium Density Fiberboard
    - b. Horizontal Splice: Heights over 16'3" [4953] with non-steel faces require a structural splice placed at approximately 12'3" [3734] from the floor.
  3. Frames shall be of 16 gauge [1.42mm] painted steel with integral factory applied aluminum vertical edge and face protection.

Optional: Face finish shall wrap around the vertical panel edges and provide no protective vertical face trim.

4. Vertical sound seals shall be of tongue and groove configuration, ensure panel-to-panel alignment and prevent sound leaks between panels.
  5. Horizontal top seals shall be fixed continuous contact dual 4-finger vinyl.
  6. All standard panels shall have bottom retractable seals which provide a minimum of 2" [51] floor clearance during movement of the partition, including all panels adjacent to pass door(s). Retractable bottom floor seal to exert downward seal force when activated. Floating or rigid seals that maintain contact with the floor during partition movement will not be acceptable.  
Optional: Bottom seals shall be fixed continuous contact 4-finger vinyl.
  7. Motor shall automatically extend/retract the bottom seals.
  8. No floor mounted seal activators are allowed.
  9. Panels must provide wall-to-wall contact for tight acoustical seal. Operable wall systems that do not extend to the back of storage pocket are not acceptable.
- B. Weight of the panels shall be 7.8-10.9 lbs. per sq. ft. [37.8-53.2 kg/sq m] based on options selected.
- C. Suspension system
1. **For panels to 900 lbs. [409 kg]:** Track shall be of clear anodized architectural grade extruded aluminum alloy 6063-T6. Track design shall provide precise alignment at the trolley running surfaces and provide integral support for adjoining ceiling, soffit, or plenum sound barrier. Guide rails and/or track sweep seals shall not be required. Track shall be connected to the structural support by pairs of minimum 3/8" [10] dia. threaded steel hanger rods.
    - a. Each panel shall be supported by one 4-wheeled carrier in the track and one internal 4-wheeled carrier. Wheels to be of hardened steel ball bearings encased with molded polymer tires.
  2. **For panels over 900 lbs. [409 kg]:** Track shall be of 1/4" formed steel. Track shall be connected to the structural support by pairs of min. 1/2" [13] dia. threaded steel hanger rods.
    - a. Each panel shall be supported by one 4-wheeled carrier in the track and one internal 4-wheeled carrier. Wheels on track carrier to be of hardened steel ball bearings. Wheels on internal carrier shall be of hardened steel ball bearings encased with molded polymer tires.
  3. Factory assembled power unit shall be UL listed and include motor, electronic torque limiter, two key control stations wired in series, emergency release, and all necessary equipment for electric operation. Roller chain drive shall attach to carrier of lead panel. Limit switches shall be provided to prevent over-travel. Motor shall be able to operate 50-60 hz and 200-240 volts, single phase with adequate horsepower to operate partition effectively.
- D. Safety Requirements:
1. Low profile hinges shall be of steel and project no more than 1/4" [6] beyond panel faces. Panels to have a minimum of three hinges.
  2. Each panel must be supported by a single carrier allowing the panels to stack freely without the use of rub rails near the pocket, thus decreasing the risk of injury while stacking into a pocket.
  3. Partition shall be operated by two (2) control stations wired in series and located on opposite sides and ends of the partition. The key stations require human contact to be activated ensuring supervised operation of the partition system.
- E. Finishes
1. Face finish shall be: **(select as required):**
    - a. Factory applied reinforced vinyl fabric with woven backing, weighing not less than 15 oz. per lineal yard [465 g/m]. Color shall be selected from manufacturer's standard color selectors.
    - b. Standard upgrade fabrics (color shall be selected from manufacturer's standard color selector):
      - (1) Factory applied vertical ribbed carpet (N.R.C. .20)
      - (2) Factory applied stain resistant fabric
  - c. Optional:
    - (1) Customer selected (requires factory approval for manufacturing compatibility)
    - (2) Unfinished for field decoration
    - (3) Wood veneer (factory installed on trimmed models)
    - (4) High pressure laminate (factory installed on trimmed models)



2. Exposed metal trim and seal color shall be (**select from Hufcor's Standard Trim selector**):
  - a. Lamb's Wool (standard)
  - b. Brown (standard)
  - c. Gray (standard)
  - d. Custom powder coated (optional upgrade for metal trim)
3. Aluminum track shall be clear anodized
  - a. Optional upgrade:
    - (1) custom anodized
    - (2) custom powder coated
- F. Available Accessories/Options (**select those required**):
  1. ADA compliant pass door of the same thickness and construction as the basic panels. Pass door leaf has perimeter trim to protect face finish and to provide visual identification as required by International Building Code.
    - a. Automatic door closer
    - b. Door lock
    - c. Exit sign (consult your local code)
    - d. Prepped for window
    - e. Peep hole
  2. Inset chalk/writing/projection surfaces
  3. Inset tackboards
  4. Inset eraser pocket
  5. Segmented faces
  6. Finished end cover
  7. Pocket doors
  8. Inset chair rail pan (for field installation of chair rail).
  9. Custom design options (consult your local Hufcor Distributor)
  10. Hufgard safety system which automatically stops the partition's forward movement when an object or person contacts the lead edge of the partition during movement.

2.03 OPERATION

- A. Partitions shall be key switch controlled, requiring constant contact to activate the motor. As a safety precaution, two key switches are

required to activate the partition. Switches to be mounted on both sides of partition to provide operators a clear view of the partition path to prevent injury.

- B. Motor drive shall automatically seal the partition in the opening. For models with retractable bottom seals, the motor automatically sets the bottom seals.

C. Stack/Store Panels

1. Panels are retracted and stored by activating the two key-switch controls.

2.04 ACOUSTICAL PERFORMANCE

- A. Acoustical performance shall be tested at a laboratory accredited by the National Voluntary Laboratory Accreditation Program (NVLAP) and in accordance with ASTM E90 Test Standards. Standard panel construction shall have obtained an STC rating of (**select as required**): 43, 47, 49, 52, 54

(Not all substrates are available in all STC ratings)

1. Complete, unaltered written test report is to be made available upon request.

PART 3 - EXECUTION

- A. Installation. The complete installation of the operable wall system shall be by an authorized factory-trained installer and be in strict accordance with the approved shop drawings and manufacturer's standard printed specifications, instructions, and recommendations.

B. Cleaning

1. All track and panel surfaces shall be wiped clean and free of handprints, grease, and soil.
2. Cartoning and other installation debris shall be removed to onsite waste collection area, provided by others.

C. Training

1. Installer shall demonstrate proper operation and maintenance procedures to owner's representative.
2. Operating keys and owners manuals shall be provided to owner's representative.

Header shown with Type 42 track. Plenum sound enclosure is one of several that may be used. See ASTM E557 Standard Practice for Archl Application & Installation of Operable Partitions for other recommendations.

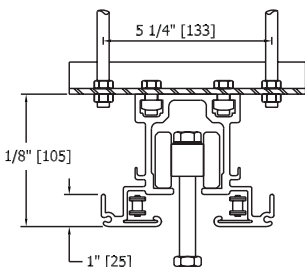
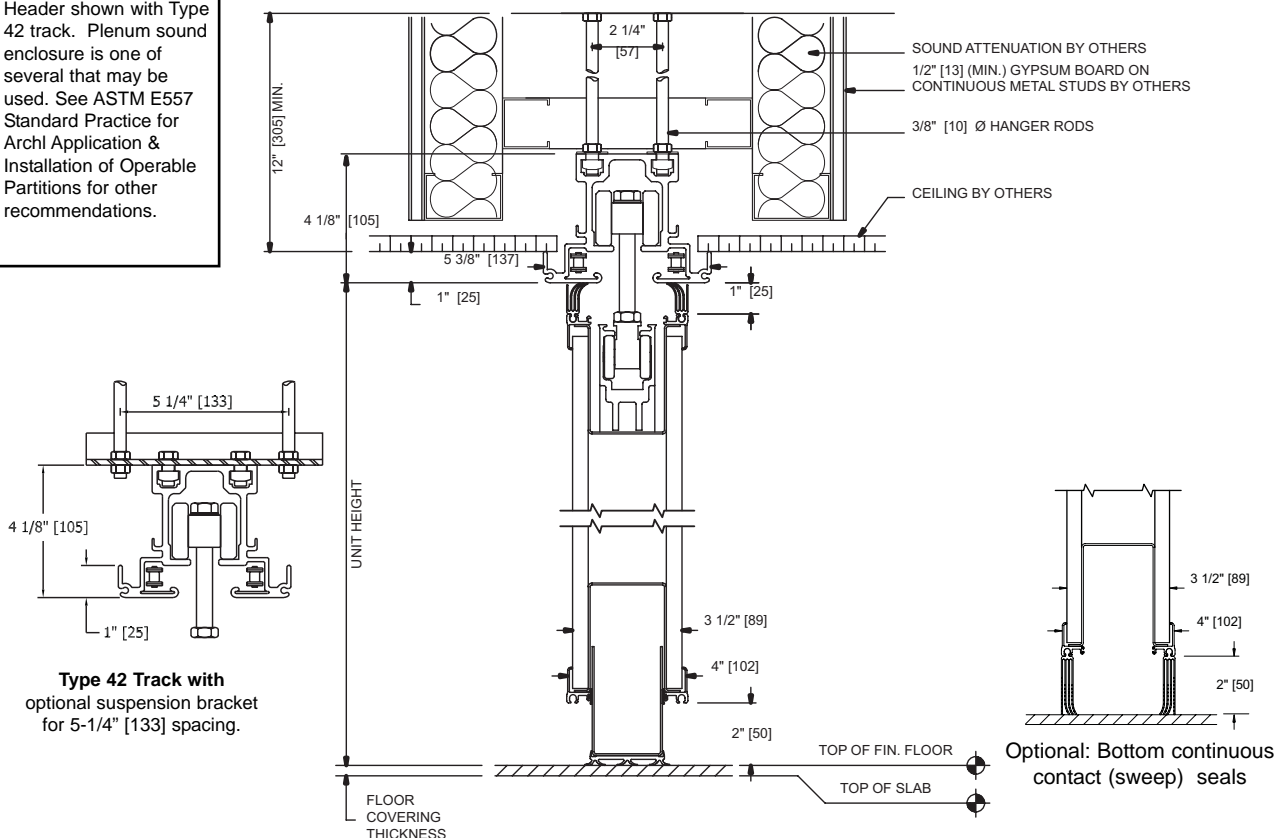

Type 42 Track with optional suspension bracket for 5-1/4" [133] spacing.

# Electrically Operated, Continuously Hinged Operable Partitions

Solid blocking required at both ends.

## HORIZONTAL SECTION (For Models with Vertical Trim)

No Scale

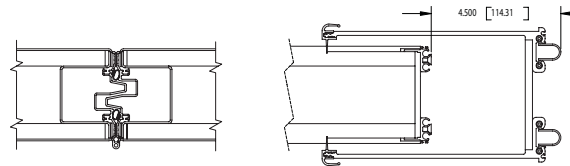
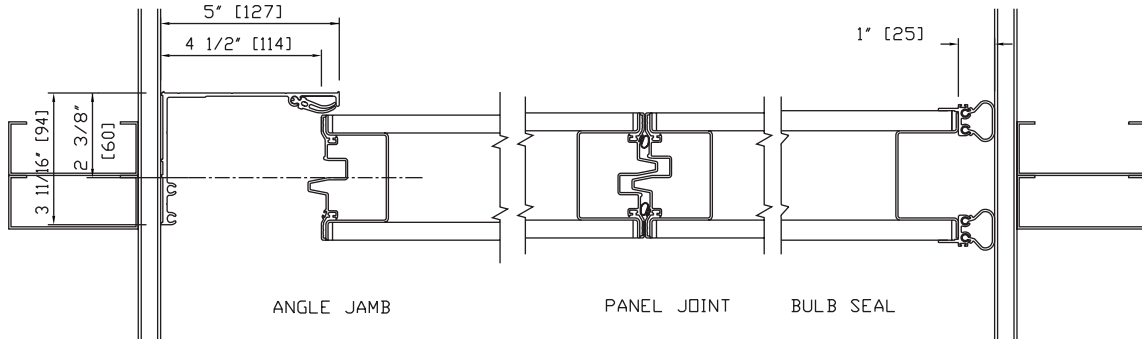

Hanging Weight		
STC	Lbs./Sq. Ft.	Kg./Sq. M
43	7.8	37.8
47	8.0	38.7
49	8.5	41.2
52	9.5	46.0
54	10.9	53.2

## OPTIONS & ACCESSORIES

## ELEVATION

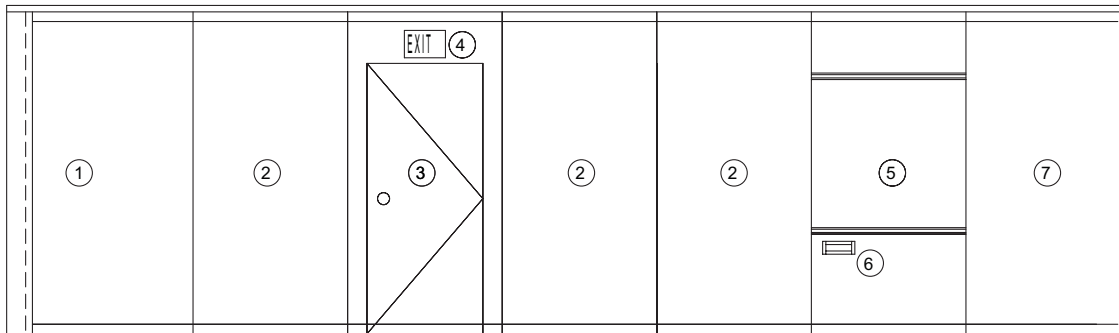

- Stack panel.** The motor drive unit closes and seals the opening.
- Basic panel**
- ADA compliant pass doors** - Single 3/0 x 7/0 [914 x 2132] or 3/0 x 6/8 [914 x 2030]. Of the same construction, thickness, and finish as the basic panels. Push/pull latching handle. Options include key lock, windows, and automatic door closer. No threshold is required.
- Exit Sign** - Recessed or surface mounted, self-illuminated.
- Work Surfaces** 4'0" [1219] high x panel width, recessed, mounted approx. 30" [762] above the floor:
  - Markerboard and projection/writing surfaces (from Hufcor standard color selector).
  - Tackboards of 2mm cork board covered with vinyl (from Hufcor standard color selector).
  - Chalk/marker tray (standard on chalk and projection/writing boards).
- Recessed Eraser Pocket** (8" x 2" x 1-1/4" deep [203 x 50 x 31]).
- Lead panel** with bulb seal to prevent sound leaks at adjacent wall.



# Electrically Operated, Continuously Hinged Operable Partitions

Top View of Motor

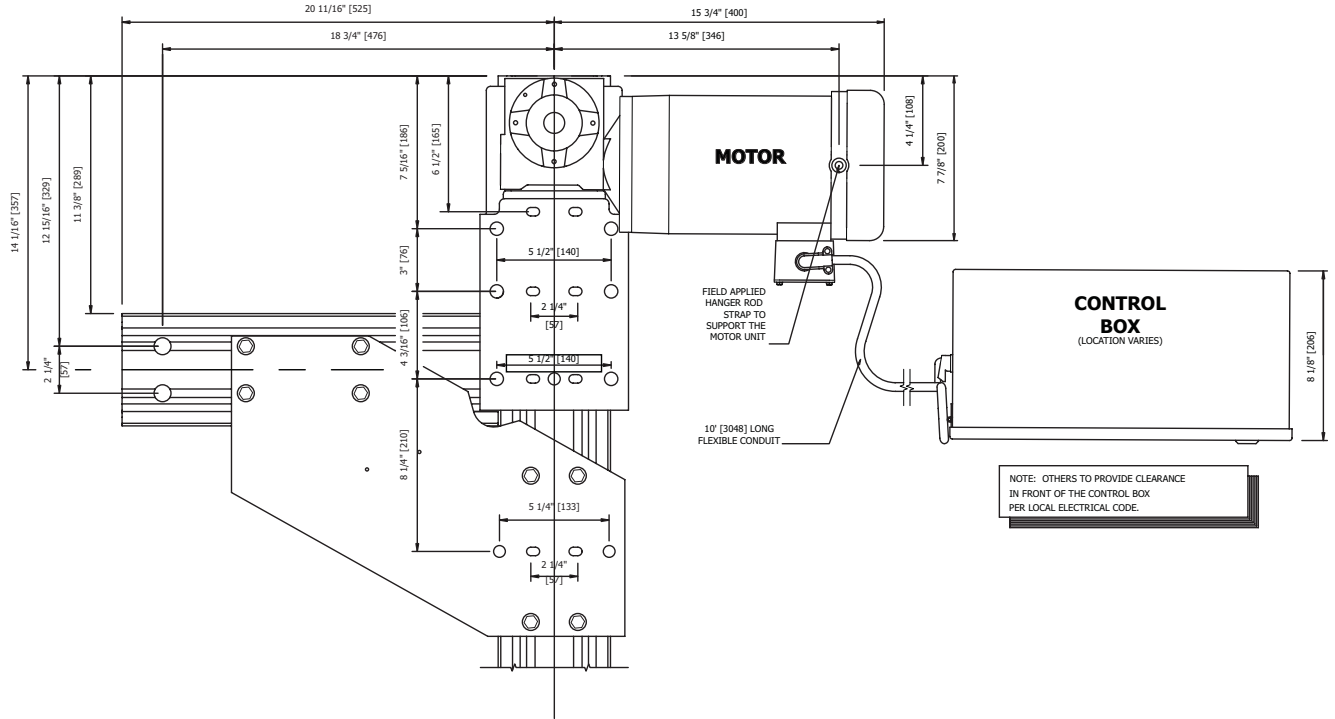

Front View of Motor

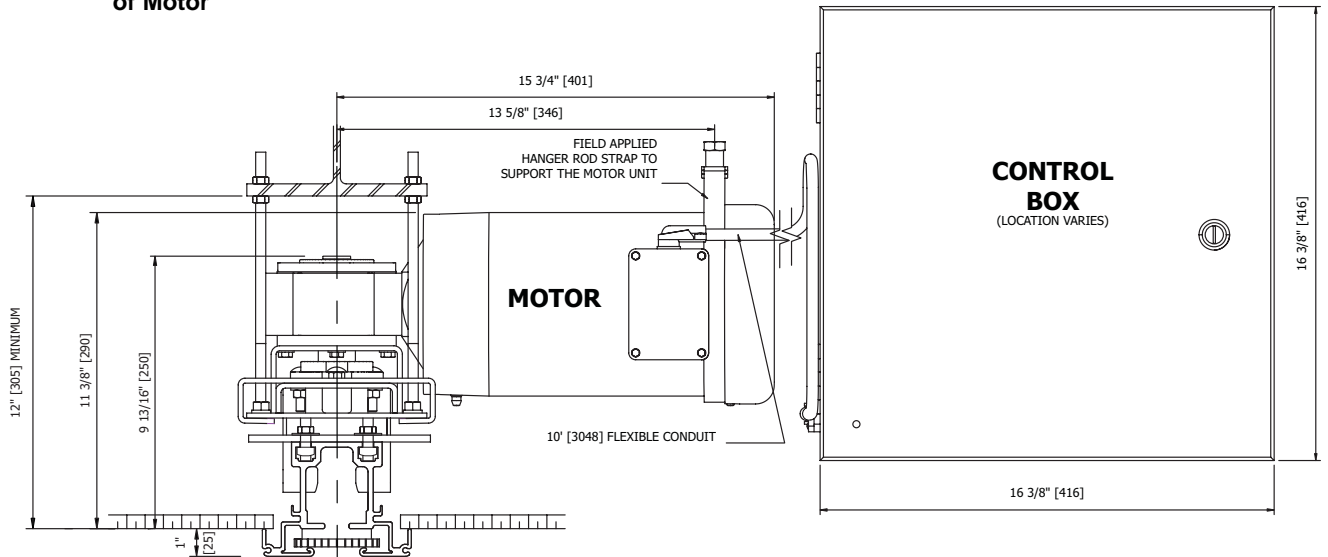

Control box not shown. The box is not fixed to the motor and can be mounted anywhere within 8' [2438] of the motor.

HANGER ROD LAYOUT - Type 42 Track

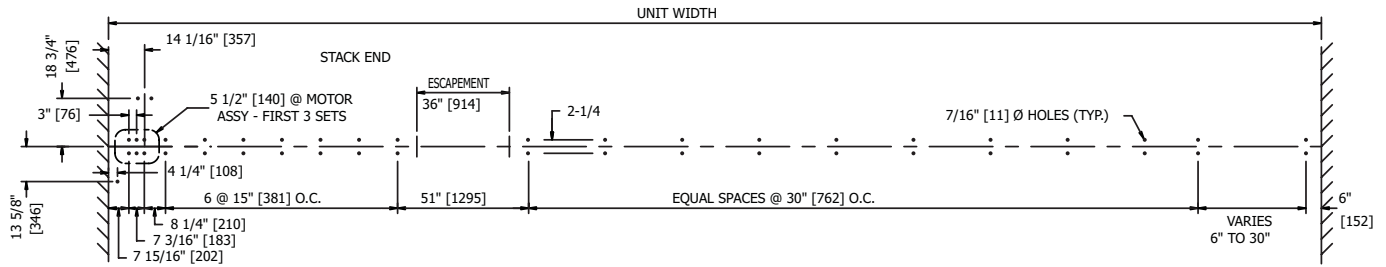

**Optional Track:**  
**Type 11 Track.** Required for panels over 900 lbs. [409 kg]. Track is of 1/4" [6] formed steel. Track trim is clear anodized aluminum. Each carrier has four steel wheels with precision ground radial bearings. Bearings are inserted into a steel tire. Tire rim fully captures the bearing. Minimum dimension from the ceiling to the structure is 12" [305].

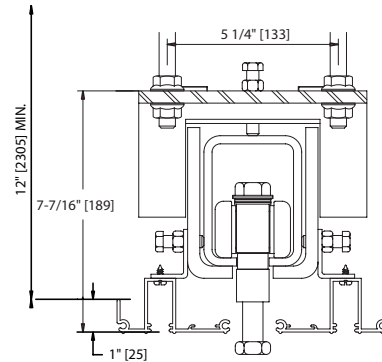

LAYOUT OPTIONS

STACK DIMENSIONS

The following stack depth and width dimensions are based on standard construction with vinyl faces. Optional construction and/or face covering may increase stack depth requirements.

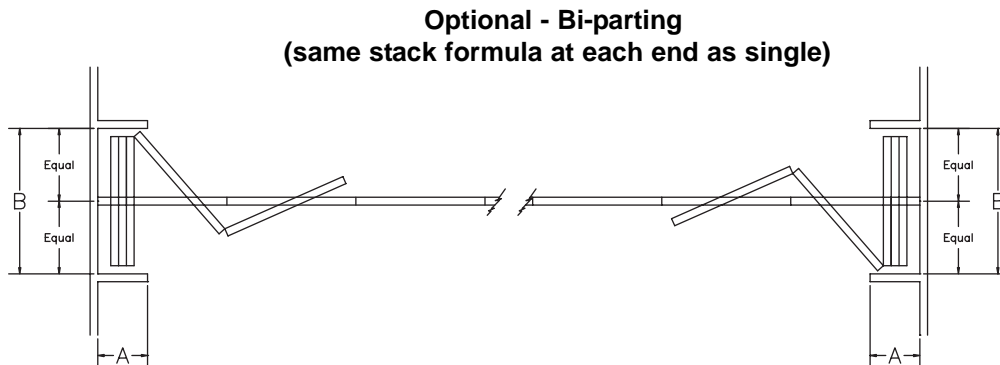
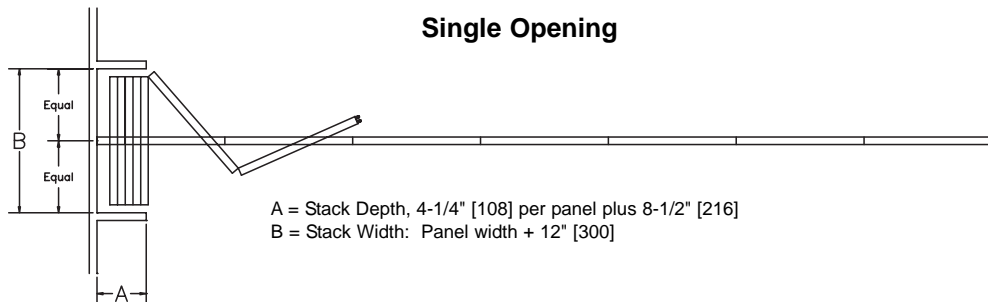

**World headquarters:**

Hufcor Inc.  
 P.O. Box 5591  
 Janesville, WI USA 53547  
 1-800-542-2371 ext. 214; 1-608-756-1241  
 FAX: 1-608-758-8253  
 E-mail: info@hufcor.com  
 Website: www.hufcor.com

The manufacturer reserves the right to improve and change product without notice.